

EUROBLOWER

Reliable, quick and
easy to order

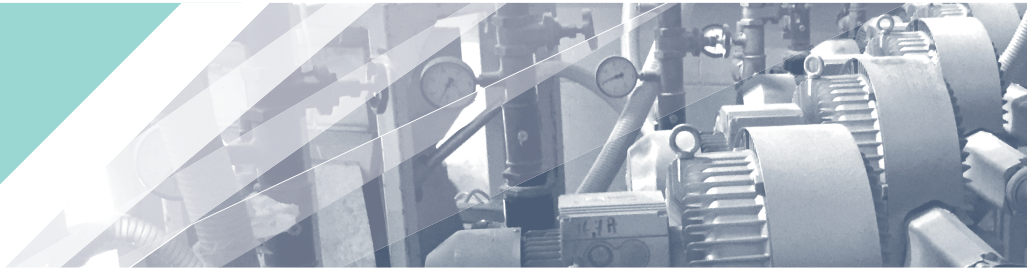

Sidechannel blower double stage EB3 2207

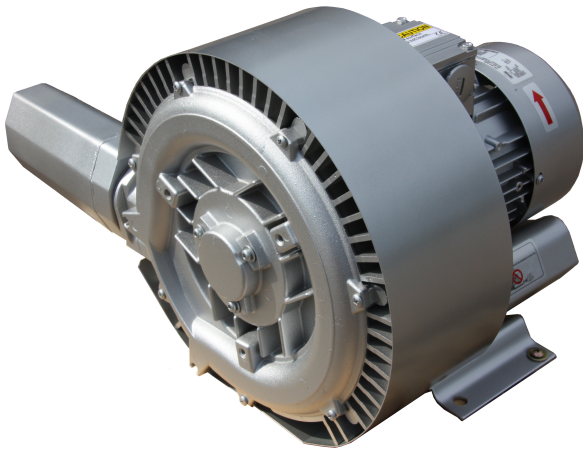

The standard Euroblower design, with housing and impeller made of aluminum alloy, is a direct drive configuration, with a dynamically balanced impeller, fitted directly on the motor shaft. The impeller rotates inside of the stator housing with a very small clearance. Larger models include housings in cast iron. The absence of lubricants guarantees a 100% oil free vacuum or compression. Construction features of the Euroblower side channel blower are the very reliable operation and low maintenance. Euroblower blowers are directly driven, impellers fixed directly on the drive shaft. Impeller bearing is installed in the front cover and easily to assemble and disassemble. Machines are small and lightweight. The blowers are already available with differential pressures up to 700 mbar.

FEATURES

- » Available from stock
- » Almost free of maintenance
- » Low power consumption
- » Oil free compression, no oil pollution in medium
- » Made of aluminum, very high corrosion resistance

AVAILABLE ACCESSORIES

- » Air filters
- » Pressure / vacuum relief valves
- » Silencers
- » Non return valves
- » Air knives
- » Fittings

EUROBLOWER

PERFORMANCE CURVES

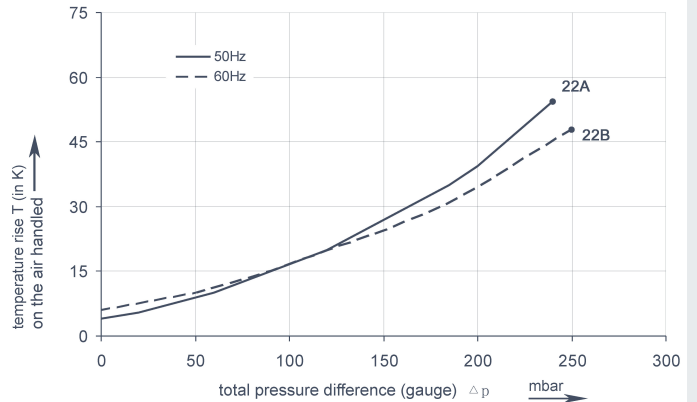
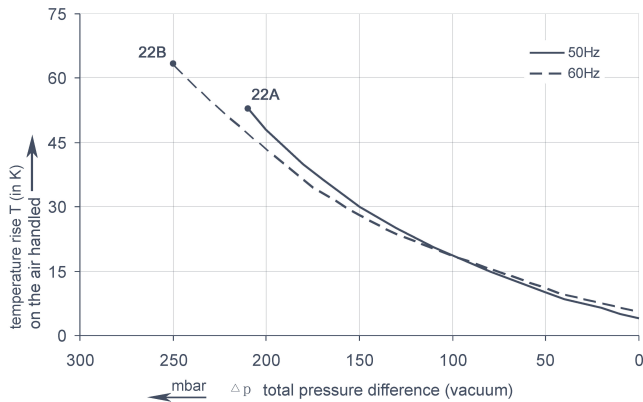
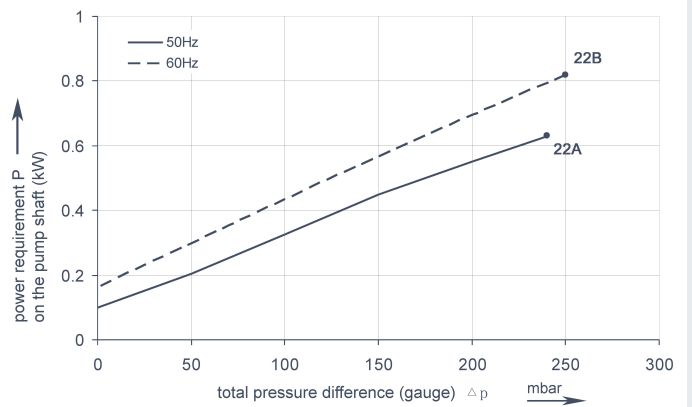
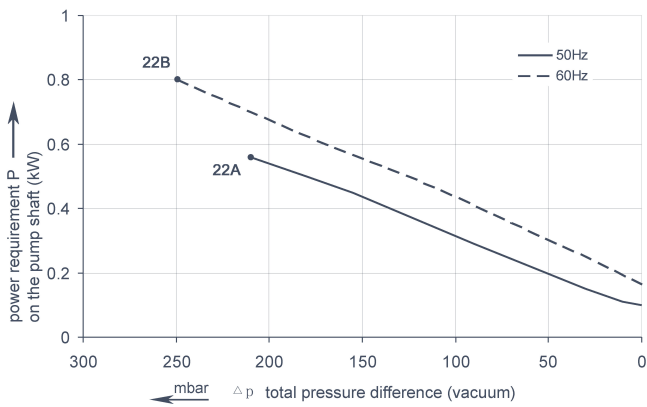
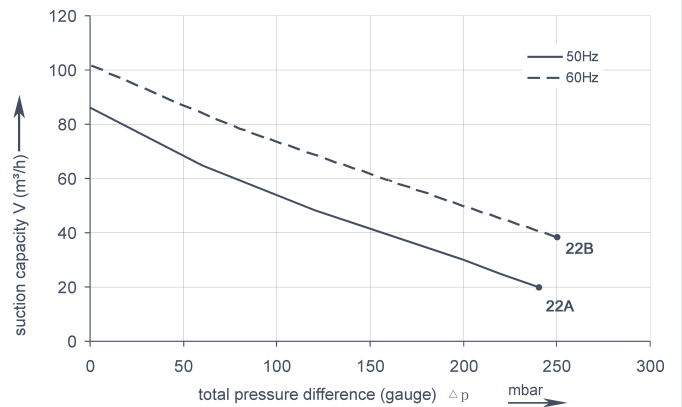
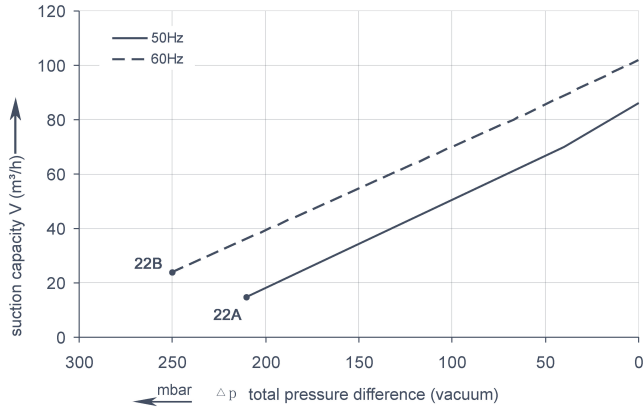

The performance curves are based on air at a temperature of 15 °C and an atmospheric pressure of 1013 mbar with a tolerance of +/- 10 %. The total pressure differences are valid for suction and ambient temperatures up to 25 °C. For other conditions please confer with us.

Each type can be applied both as vacuum pump and compressor in continuous operation over the total stated performance curve range. The motors are available as standard for the input voltage range of 50 and 60 Hz.

EUROBLOWER

SELECTION AND ORDERING DATA

TYPE EB3 2207

Curve No.	Order No.	Fre- quency Hz	Rated power kW	Input voltage		Input current		Permissible total differential pressure ²⁾		Sound pressure level ³⁾ dB(A)	Weight ca. kg
				V		A		Vacuum mbar	Compressor mbar		
22A	EB3 2207	50	0.7	200D...240D	345Y...415Y	3.8D	2.2Y	-210	240	55	15
22B	EB3 2207	60	0.83	220D...275D	380Y...480Y	3.75D	2.15Y	-250	250	61	15



All EB3 and EB1 sidechannel blowers achieve the standards and norms of the low voltage directive (LVD)2006/95/EC, rotating electrotechnical motor EN 60034-1-2004, electromagnetic compatibility(EMC)EN55014-1/2,EN61000-2/-3/-4/-6.

1) Relief-valve are available for limiting differential pressure.
2) Measuring-surface sound-pressure level acc. to DIN EN 21680, measured at a distance of 1 m. The pump is throttled to an average suction pressure, a hose is connected to the discharge side (compressor) / suction side (vacuum pump), but is not fitted with relief valves.

The motors are designed according to the DIN EN 60 034 / DIN IEC 34-1 and temperature class F.

For the three phase machines the tolerances are +/- 10 % for fixed voltage and +/- 5 % for voltage range.

The single phase machines are designed with a +/- 5 % tolerances. If only 90 % of the maximum allowed pressure will be used for the continuous operating then the allowed voltage range add to +/- 10 %.

The frequency tolerance is maximum +/- 2 %.

EUROBLOWER

DIMENSIONS IN MM

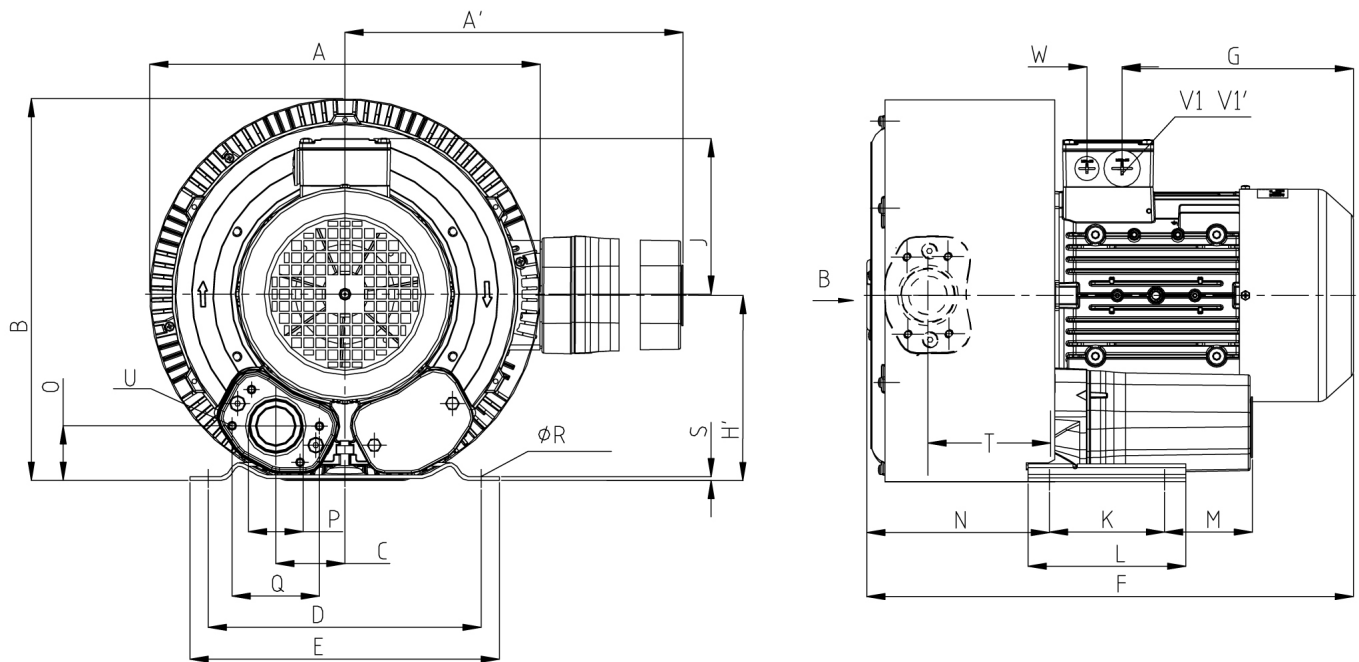

Curve No.	Type	A	A'	B	C	D	E	F	G	H	H'	J	K	L	M
22A / 22B	EB3 2207	284	316	270	45	205	230	316	135	128	106	111	83	108	75
Curve No.	Type	N	O	P	Q	Ø R	S	T	U	V1	V'1	Ø X	YxZ	X-holes	
22A / 22B	EB3 2207	130	39	G 1 ¼"	64	10	2.5	88	M6 x 17	M25 x 1.5	M16 x 1.5	140	M6 x 1.5	51° / 171° / 291°	